

DIMENSÕES

RED.	A	B	C	D	E	F	G	H	I	L	M	N	P	Q	J	K
SC-00	123	80.5	33.5	28	11	42	85	35	16	80	8.5	16	53	100	60	
SC-01	154	95.25	48.5	30	16	60	90	40	19	114	8.5	19	82	100	65	45
SC-02	189	117.5	59.5	40	19	73	108	45	23	134	10.5	23	90	120	82	50
SC-03	235	152	79	55	24	94.5	131.5	60	29	172	10.5	29	124	145	95	70
SC-04	300	185	103	60	28	120	154	70	42	222	16	42	170	175	118	90
SC-05	360	208.5	130	70	32	140	178	80	46	275	19	46	195	220	150	120
SC-06	430	256	154	80	38	175	217.5	100	55	322	22	55	240	250	150	160
SC-07	515	310	180	90	40	225	255	120	65	392	22	65	310	290		

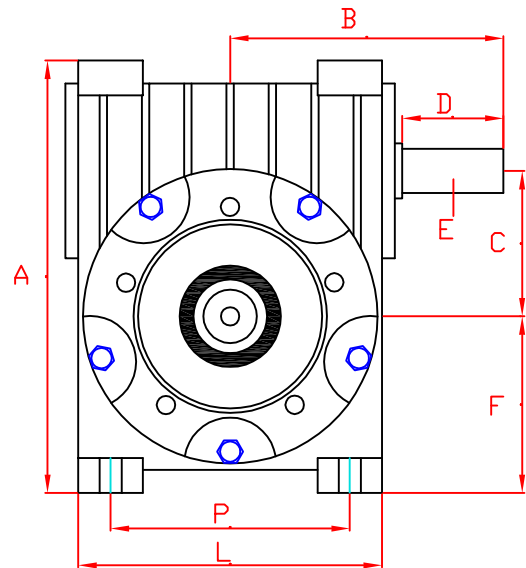

RED.	CARC.B14	A	B	C	D	E	F
SC-00	56b	120	100	80	30	5	6.5
	63a	140	115	95	30	6.5	6.5
	71a	160	130	110	30	6.5	6.5
SC-01	63b	140	115	95	40	6.5	6.5
	71a	160	130	110	40	6.5	6.5
	80a	200	165	130	40	8.5	6.5
SC-02	63b	140	115	95	40	6.5	6.5
	71a	160	130	110	40	6.5	6.5
SC-03	80a	200	165	130	40	8.5	6.5
	80a/90L	200	165	130	50	8.5	8.5
SC-04	80a/90L	200	165	130	60	8.5	8.5
	100L	250	215	180	60	10.5	8.5
SC-05	80a/90L	200	165	130	60	8.5	8.5
	100L/112M	250	215	180	60	10.5	8.5
SC-06	90L	200	165	130	80	8.5	10.5
	100L/112M	250	215	180	80	10.5	10.5
SC-07	132S	300	263	230	80	10.5	10.5
	112M	250	215	180	80	10.5	10.5
	132S/M	300	263	230	80	10.5	10.5

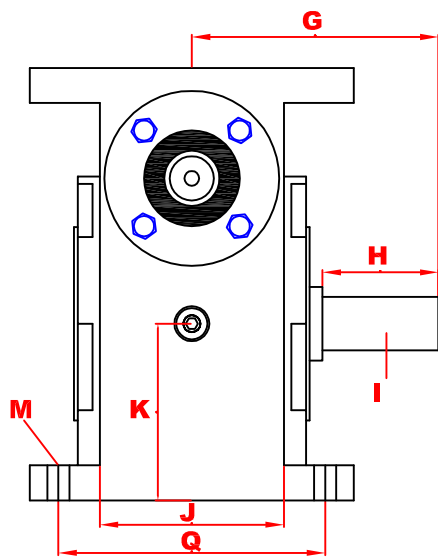